

**NOTES:**

1. Intentionally left blank
2. Steel reinforcement: A.S.T.M. A496-A615 Grade 60-60 ksi
3. Joints sealed with Conoseal CS101 Butyl Mastic
4. Concrete: 4000 psi @ 28 days, 5% - 9% air entrainment with 5 lbs / cu. yd of fiber mesh
5. Equipped with polylok seals
6. Intentionally left blank
7. Design loading A-0.3/ 300 psf - walkways, floatation forces not accounted for
8. Max. cover over tank: 3' of earth fill
9. Min. 1" concrete cover over reinforcement
10. Tank to conform with ASTM C1227

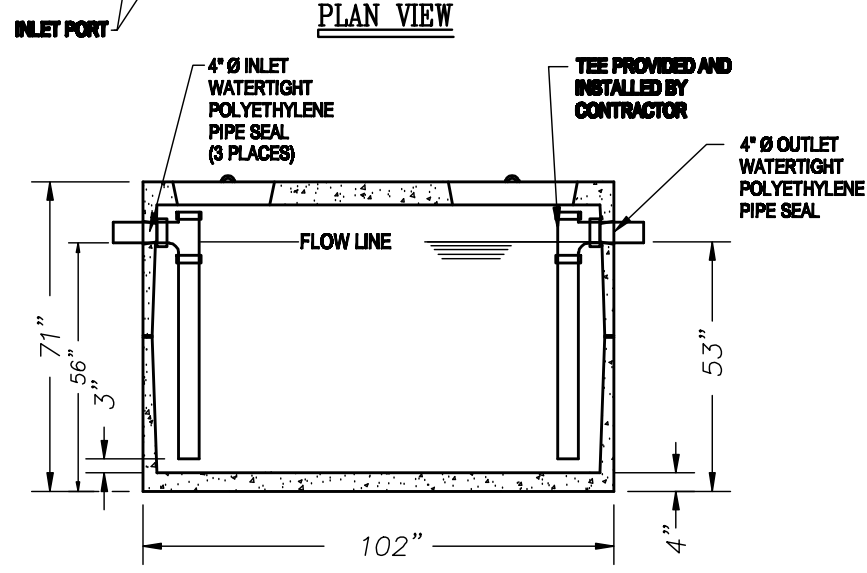

NOTE: PUMP TANK DOES NOT INCLUDE TEE BAFFLES

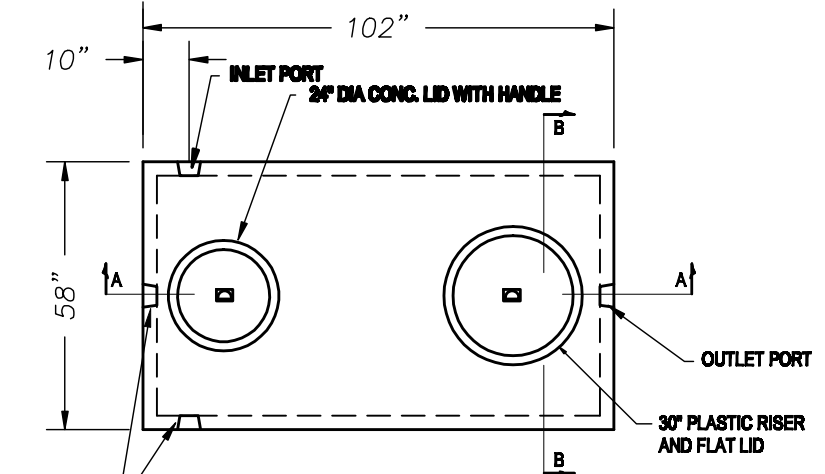