

VERIFY SIZE OF INLET PORT WITH BUYER PRIOR TO FABRICATION (IF INLET PORT WILL NOT HAVE POLYLOK SEAL)

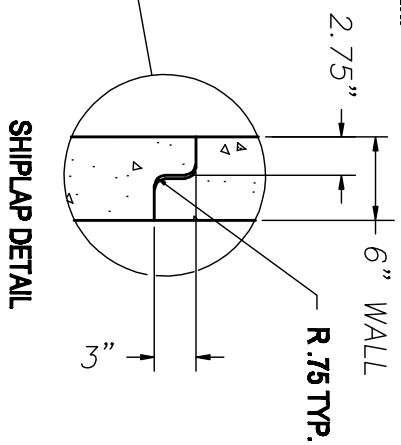

- NOTES:**
1. Joints sealed with Consenal CS101 Butyl Mastic
  2. Concrete: 5000 psi @ 28 days, 5% - 9% air entrainment with 5 lbs / cu. yd of fiber mesh
  3. Equipped with Kor n Seal seals 4'-6" or Equivalent
  4. Design loading H-20 / ASTM C857
  5. Min. 1" concrete cover over reinforcement
  6. Tank to conform with ASTM C1227
  7. Steel reinforcement: #4 rebar vertically 12" o.c. and #5 rebar horizontally 12" o.c. A.S.T.M. A496-A515 Grade 60-60 ksi
  8. Entire exterior of (4) side walls, and bottom, sealed Consenal CS-55 coating

DRAWING NUMBER: 3500-ST 1/5/21

PRODUCT SPECIFICATION 3500 GALLON SEPTIC TANK

