

**NOTES:**

1. Two compartment mid-depth
2. Steel reinforcement: A.S.T.M. A496-A615 Grade 60-60 ksi
3. Joints sealed with asphalt cement or equal
4. Concrete: 4000 psi @ 28 days, 5% - 9% air entrainment
5. Equipped with polylok seals
6. Intentionally left blank
7. Design loading A-0.3/ 300 psf - walkways, flotation forces not accounted for
8. Max. cover over tank: 3' of earth fill
9. Min. 1" concrete cover over reinforcement
10. Tank to conform with ASTM C1227

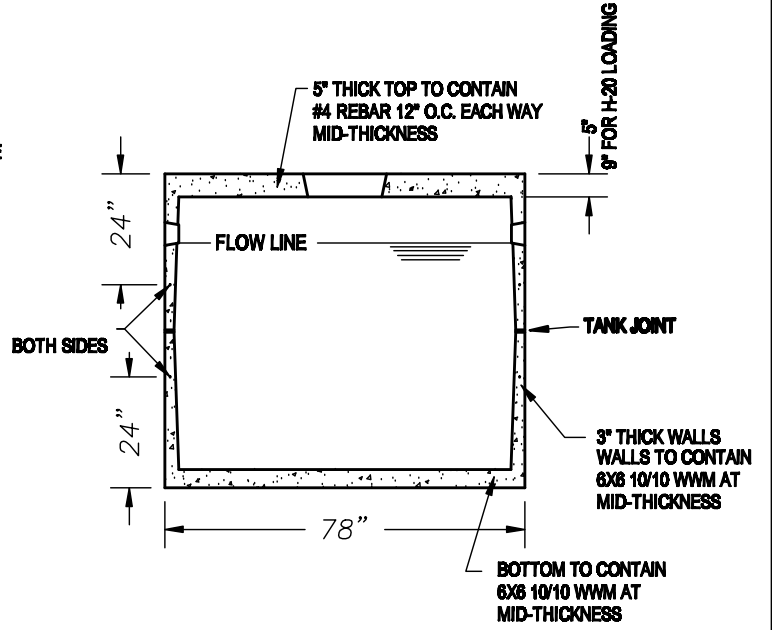
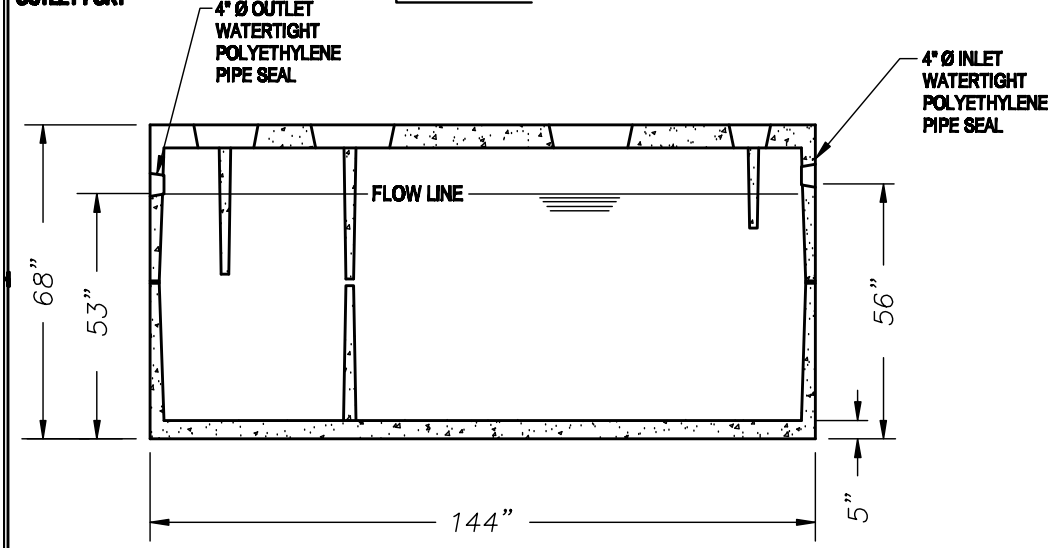
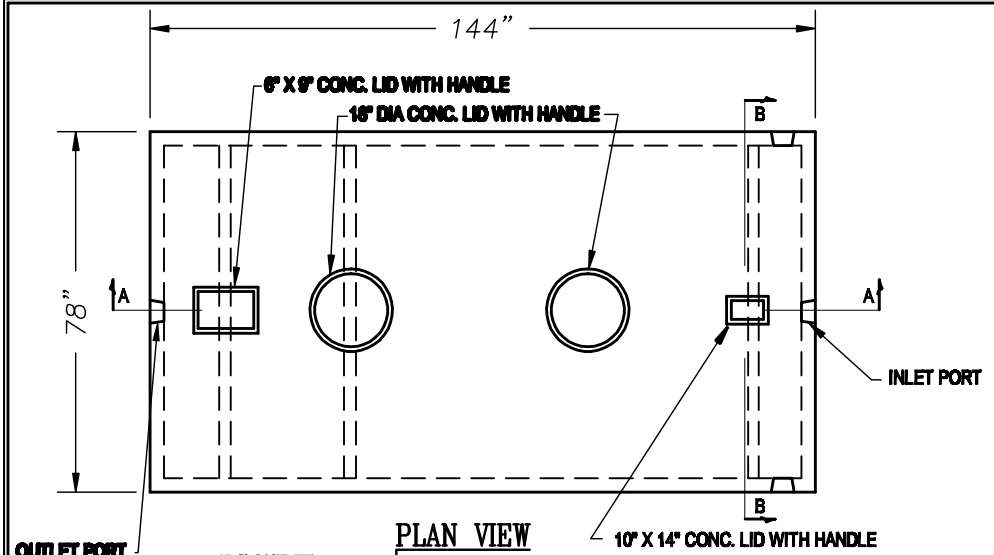

SECTION A-A

SECTION B-B