

NOTES:

1. Joints sealed with Conseal CS101 Butyl Mastic
2. Concrete: 5000 psi @ 28 days, 5% - 9% air entrainment with 5 lbs / cu. yd of fiber mesh
3. Equipped with Kor n Seal seals 4"-6" or Equivalent
4. Design loading H-20 / ASTM C857
5. Min. 1" concrete cover over reinforcement
6. Tank to conform with ASTM C1227
7. Steel reinforcement: #4 rebar vertically 12" o.c. and #5 rebar horizontally 12" o.c. A.S.T.M. A496-A615 Grade 60-60 ksi

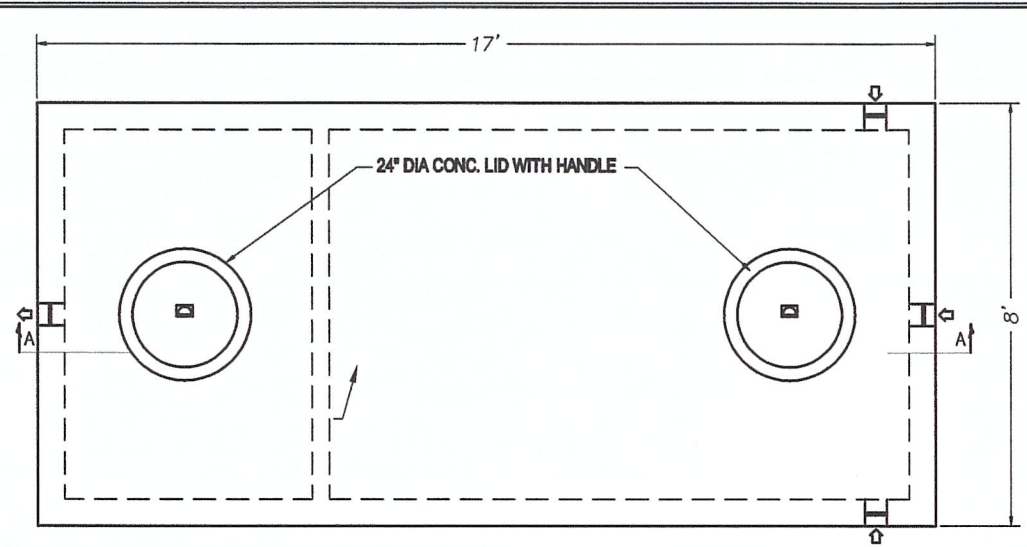

PLAN VIEW

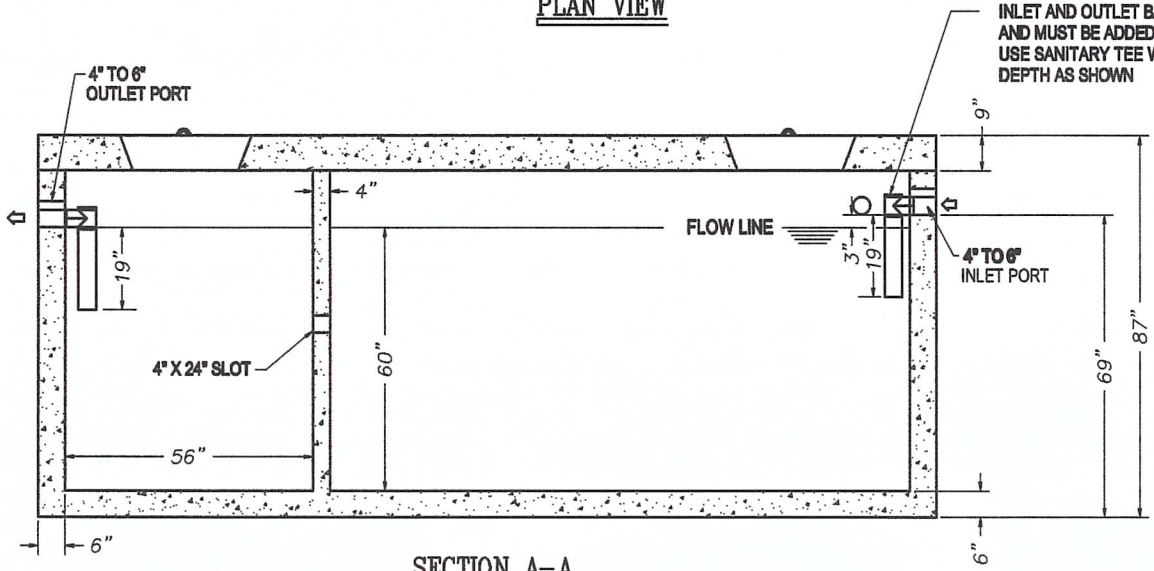

SECTION A-A

INLET AND OUTLET BAFFLES NOT INCLUDED
 AND MUST BE ADDED AFTER INSTALLATION.
 USE SANITARY TEE WITH PIPE EXTENSION TO
 DEPTH AS SHOWN