

SECTION A-A

LENGTH	LOW LEVEL	DRAW	DOSE
102"	4"	6"	186 Gal
102"	4"	11"	228 Gal
102"	4"	13"	270 Gal
102"	4"	17"	353 Gal
102"	4"	20"	416 Gal

- NOTES:**
1. Intentionally left blank
 2. Steel reinforcement: A.S.T.M. A496-A615 Grade 60-60 ksi
 3. Joints sealed with asphalt cement or equal
 4. Concrete: 4000 psi @ 28 days, 5% - 9% air entrainment with 5 lbs / cu. yd of fiber mesh
 5. Equipped with polylok seals
 6. Intentionally left blank
 7. Design loading A-0.3/ 300 psf - walkways, flotation forces not accounted for
 8. Max. cover over tank: 3' of earth fill
 9. Min. 1" concrete cover over reinforcement
 10. Tank to conform with ASTM C1227

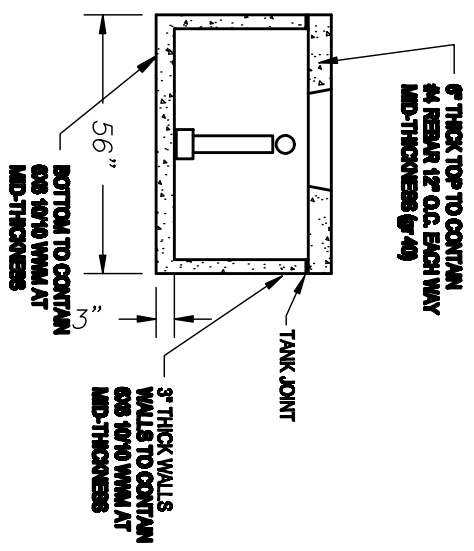

SECTION B-B